



WATER



GAS



ENVIRONMENT



PEST CONTROL

KITCHEN FAUCETS/TAPS & SPOUTS

SUITABILITY: Light Medium Heavy

DECK MOUNTED - MONOBLOC

DELABIE

SINGLE HOLE SINGLE WATER FEED ONE CONTROL

1/2" DOME HEAD SINK TAP WITH SWIVEL SPOUT

Sold individually.

Model	Description
DLB-D-2553	150mm Swivel Spout

PANEL MOUNTED - SINGLE FEED

DELABIE

SINGLE HOLE SINGLE WATER FEED ONE CONTROL

1/2" DOME HEAD BIB TAP WITH SWIVEL SPOUT

See page 61 for backplate elbow

Model	Description
DLB-D-275-200	200mm swivel spout, scale-proof flow straightener

1/2" DOME HEAD STOP VALVE

Model	Description
DLB-D-273015	Tap control (stop valve) for spouts M 1/2-inch

DECK MOUNTED - MONOBLOC MIXER

DELABIE

SINGLE HOLE TWIN WATER FEED ONE CONTROL

3/8" MIXER TAP WITH LEVER CONTROL AND SWIVEL SPOUT

Spray head can pull out and extend to approximately 1-metre

With Ergo control lever.

Model	Description
DLB-2211	Single Lever Mixer with swivelling spout and retractable spray head

3/8" MIXER TAP WITH LEVER CONTROL AND SWIVEL SPOUT

DLB-2506T2

Worktop hole: 34mm
Flow rate: 3 bar
DLB-2506T2: L per M: 5
DLB-2506T3: L per M: 20

Model	Description
DLB-2506T2	200mm Swivel Spout, OA 300mm
DLB-2506T3	300mm Swivel Spout, OA 400mm



WATER



GAS



ENVIRONMENT



PEST CONTROL

KITCHEN FAUCETS/TAPS & SPOUTS

SUITABILITY: Light Medium Heavy

DECK MOUNTED - MONOBLOC MIXER

DELABIE

SINGLE HOLE TWIN WATER FEED ONE CONTROL

3/8" MIXER TAP WITH LEVER CONTROL AND SWIVEL SPOUT

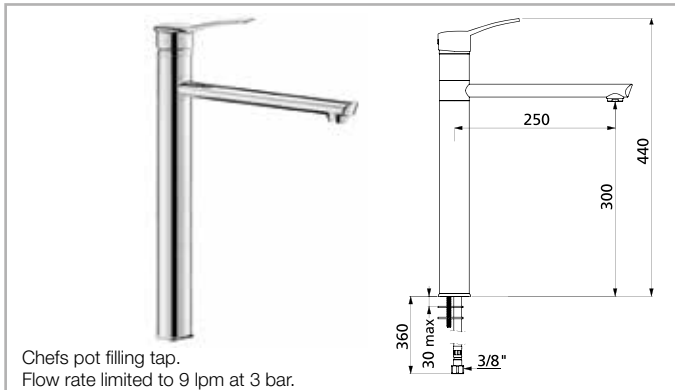

Chefs pot filling tap.
Flow rate limited to 9 lpm at 3 bar.

Model	Description
DLB-2564T4	Mechanical mixer for sinks or troughs with swivelling spout



1/2" MIXER TAP WITH LEVER CONTROL AND SWIVEL SPOUT

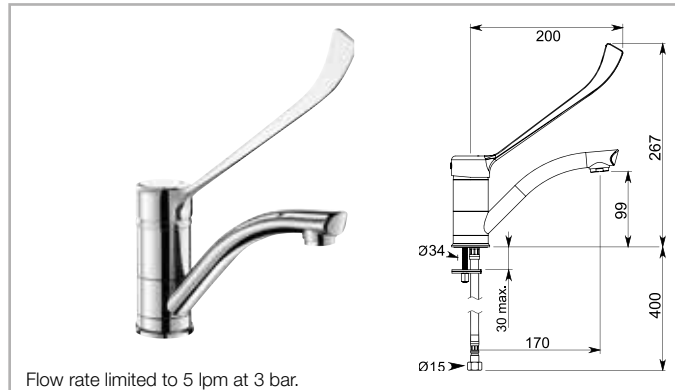

Flow rate limited to 5 lpm at 3 bar.

Model	Description
DLB-2522L	Mechanical basin mixer with swivelling spout



WALL MOUNTED - MONOBLOC MIXER

DELABIE

TWIN HOLE TWIN WATER FEED ONE CONTROL

1/2" MIXER TAP WITH LEVER CONTROL AND SWIVEL SPOUT



Wall-mounted sink mixer.
Flow rate limited to 5 lpm at 3 bar.

Model	Description
DLB-2446LS	Swivelling, flat under-spout



ACCESSORIES - UNIONS & FITTINGS

DELABIE

For Wall-Mounted Pre-Rinse Sprays (PRS) & Wall-Mounted Faucets

1/2" CONNECTIONS FOR WALL-MOUNTED UNITS

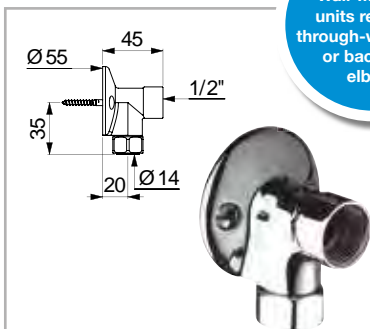

Model	Description
DLB-841-315	Elbow connector for M1/2" stopcocks

All Wall-Mounted units require a through-wall fitting or backplate elbow.

3/4" CONNECTIONS FOR WALL-MOUNTED UNITS

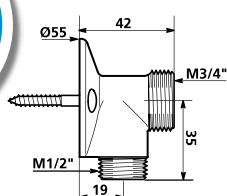

DLB-841-327-2P

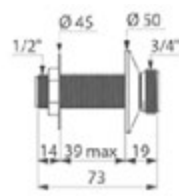

DLB-846-427-2P

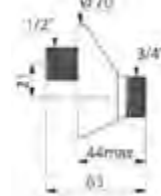

DLB-857-027-2P

Model	Description
DLB-846-427.2P	Straight Union through-wall fitting (2 pack)
DLB-841-327.2P	Backplate Elbow for Mixer Tap G-6679/G-6681 (2 pack)
DLB-856-027-2P	S-Union through-wall fitting (offset) - 12.5mm (2 pack)
DLB-857-027-2P	S-Union through-wall fitting (offset) - 21mm (2 pack)



DLB-856-027-2P



WATER



GAS



ENVIRONMENT



PEST CONTROL

KITCHEN FAUCETS/TAPS & SPOUTS

SUITABILITY: Light Medium Heavy

UNIVERSAL TELESCOPIC - SPOUTS

DELABIE

BOWL FILLING SPOUT (BIB TAP)

Options for Pre-Rinse Sprays (PRS) and Faucets

Model	Description
DLB-966-230	Universal Telescopic Spout, F 3/4-inch, L 200-290mm
DLB-966-380	Universal Telescopic Spout, F 3/4-inch, L 300-470mm

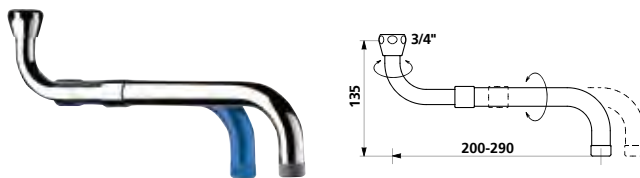

DECK MOUNTED - SPOUTS

DELABIE

FIXED, CAST SPOUT

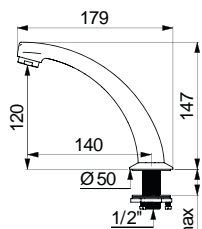

- Chrome-plated solid brass.
- Reinforced fixing by 3 stainless steel screws.
- Flow straightener set at 3 lpm.

Model	Description
DLB-981-142	L 140, H 120mm, M1/2"

DECK MOUNTED SWAN NECK SWIVEL SPOUT

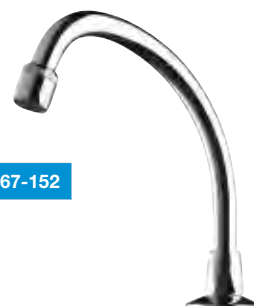
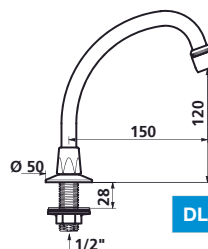

Model	Description
DLB-967-152	L 150, H 120, M1/2"
DLB-967-202	L 200, H 200, M1/2"

DECK MOUNTED SWIVEL SPOUT, Ø 22

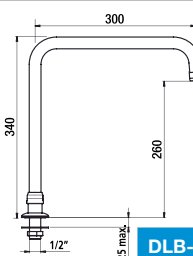
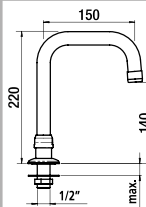

Model	Description
DLB-1306T1	L 150, H 140, OA 220mm, M1/2"
DLB-1306T2	L 200, H 260, OA 340mm, M1/2"
DLB-1306T3	L 300, H 260, OA 340mm, M1/2"

M 1/2-inch, chrome-plated brass spout on a base plate. Smooth interior to prevent bacteria build-up. Flow straightener (flow rate can be adjusted if pressure < 3 bar)

Model	Description
DLB-1306T1	L 150, H 140, OA 220mm, M1/2"
DLB-1306T2	L 200, H 260, OA 340mm, M1/2"
DLB-1306T3	L 300, H 260, OA 340mm, M1/2"

BASIX

IMPROVE WATER SAVING AND HYGIENE WITH A HANDS-FREE WASH STATION



See pages 85-97 for details

PANEL MOUNTED - SPOUTS

DELABIE

WALL MOUNTED SPOUT "CORBIN" FOR PANEL < 10 MM

WALL MOUNTED SPOUT, Ø 32



Model	Description
DLB-941-922	Scale-proof flow straightener set at 3 lpm. L 120mm



Chrome-plated brass.

Model	Description
DLB-947-170	Scale-proof flow straightener set at 3 lpm. L 160mm



WATER



GAS



ENVIRONMENT



PEST CONTROL

KITCHEN FAUCETS/TAPS & SPOUTS

SUITABILITY: Light Medium Heavy

TEMPOSOFT 2 - TIME FLOW BASIN CONTROLS

DELABIE

TEMPOSOFT 2 - AUTOMATIC SHUT-OFF, TIME FLOW TAP WITH SOFT-TOUCH OPERATION

- Deck-mounted time flow basin tap
- Soft-touch operation
- Water-savings up to 85%
- WRAS-approved
- Smooth design to significantly reduce the risk of bacterial development
- Time flow 7 seconds
- Flow rate pre-set at 3 lpm at 3 bar, can be adjusted from 1.5 to 6 lpm
- Tamperproof scale-resistant flow straightener
- Solid chrome-plated brass body

Worktop hole: 21mm

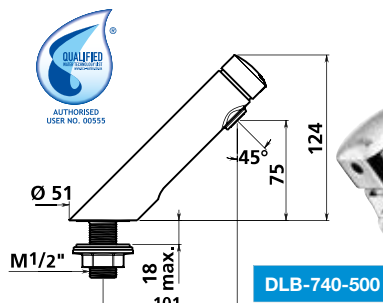

DLB-740-500

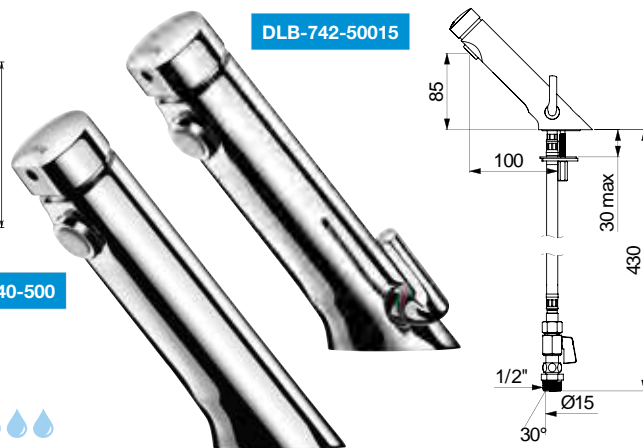

DLB-742-50015

Model	Description
DLB-740-500	Temposoft 2. M1/2" fixing with back-nut
DLB-742-50015	Temposoft Mix 2. Ø 15mm for compression fittings

TIMEFLOW - BASIN CONTROLS

DELABIE

TEMPOSTOP AUTOMATIC SHUT-OFF BASIN TAP

TEMPOSTOP AUTOMATIC SHUT-OFF WASH-BASIN TAP

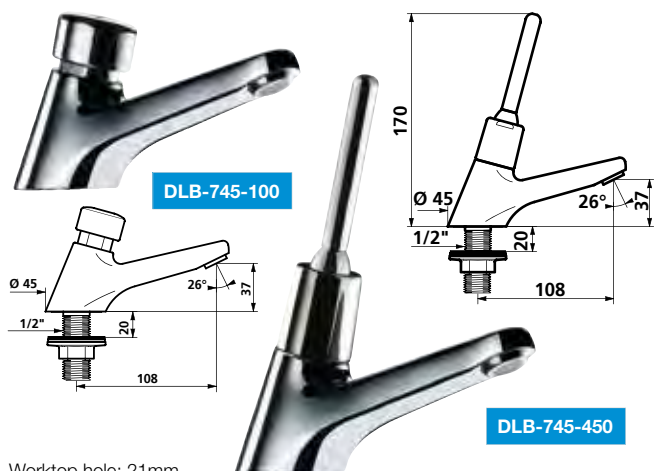

DLB-745-100

DLB-745-450

Worktop hole: 21mm

Model	Description
DLB-745-100	Push-button basin tap
DLB-745-450	Lever-operated basin tap

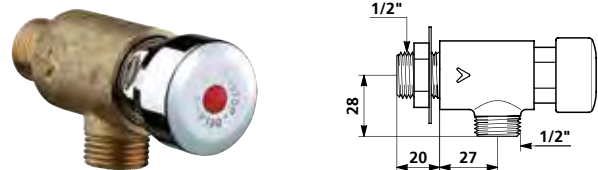

Model	Description
DLB-748-626	Push-button wash-basin tap

TEMPOSTOP AUTOMATIC SHUT-OFF BIB TAP



Model	Description
DLB-746-000	Push-button bib tap

ACCESSORIES - USEFUL OPTIONS

Fix-A-Tap Gaskets

1/2-inch Fix-A-Tap gaskets prevent taps from swiveling on stainless steel sinks. Made of durable plastic, they are a long-lasting and an essential accessory.

Model	Description
FXT50	(minimum quantities 5)



Brass Back Nuts

Model	Description
10BBN-1/2	1/2-inch Brass back nuts (pack of 10)

Note: Supplied as standard on all WRAS-approved models in the CaterTap range.



Tap Hole Stopper

Model	Description
THS	To cover unused tap holes in basins. Fits tap hole sizes up to 35mm





WATER



GAS



ENVIRONMENT



PEST CONTROL

KITCHEN FAUCETS/TAPS & SPOUTS

SUITABILITY: Light Medium Heavy

FOUNTAIN WATER FITTINGS

FOUNTAIN PILLAR TAPS

Model	Description
DLB-311-TR1	Fountain Pillar Tap, Swan neck with inlet for Rilsan tube 4x6 (push-on fitting)
DLB-311-QU1	Same as 311 TR1, with inlet M 3/8-inch

DELABIE

BUBBLERS

- Bubbler for water fountains
- Instant shut-off
- Adjustable flow rate
- Chrome-plated brass

Model	Description
DLB-312-TR1	Bubbler tap with inlet for Rilsan tube 4x6
DLB-312-QU1	Bubbler with inlet M 3/8-inch

PUSH-BUTTON TAP WITH INSTANT SHUT-OFF

For swan neck pillar taps and bubblers

Model	Description
DLB-319-T61	Connectors for Rilsan tube 4x6

MAINTENANCE PARTS

Model	Description
DLB-743-010	Tempostop complete cartridge for models 745-100, 746-000, 748-626
DLB-743-310	Tempostop complete cartridge for model 745-450
DLB-743-323	Tempostop complete cartridge for models 737-152, 737-202
DLB-753-010	Tempostop maintenance bag for models 745-100, 746-000, 748-626
DLB-753-303	Tempostop maintenance bag for models 737-152, 737-202
DLB-925-622.2P	Scale proof Aerator (with economy washer) F22 (2 pack)
DLB-925-624.2P	Scale proof Aerator (with economy washer) M24 (2 pack)
DLB-366-015.2P	Valve head with no control knob (2 pack)
DLB-816	Replacement retractable spray head (for mixer 2211)

If you cannot find a part number and price for what you require, please contact Mechline for assistance



WATER



GAS



ENVIRONMENT



PEST CONTROL

ELECTRONIC, HANDS FREE TAPS & ACCESSORIES

DELABIE

DECK MOUNTED - ELECTRONIC & BATTERY-OPERATED CONTROLS

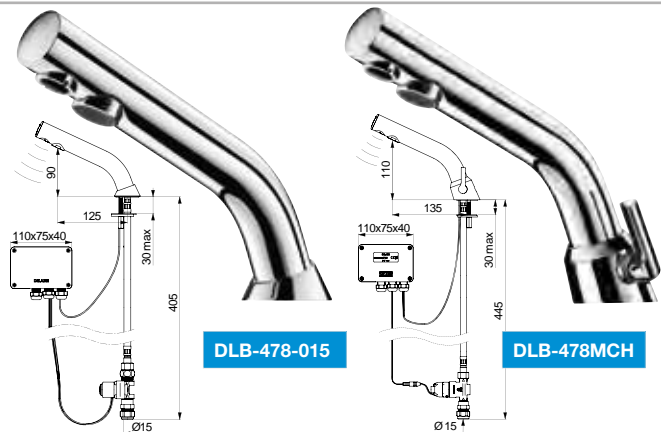

DLB-478-015

DLB-478MCH

BINOPTIC Mix / BINOPTIC - BATTERY operated models

Deck-mounted electronic basin tap.

- Independent IP65 electronic control unit.
- 123 6V Lithium battery-operated.
- 15mm connector for compression fittings.
- Flow rate pre-set at 3 lpm at 3 bar, can be adjusted from 1.5 to 6 lpm.
- Scale-resistant flow straightener.
- Adjustable duty flush (pre-set flush ~60 sec. every 24hr after last use).
- Active, infrared presence detection, sensor at the end of the spout
- optimises detection.
- Chrome-plated brass body.
- PEX flexible with filter and solenoid valve.
- Reinforced fixing.
- Anti-blocking safety.
- Spout with smooth interior and low volume of water (reduces bacterial niches).
- Side temperature control with adjustable maximum temperature limiter (478MCH15 model only).

Model	Description
DLB-478-015	BINOPTIC sensor tap - BATTERY operated model
DLB-478MCH	BINOPTIC mixer tap - BATTERY operated model

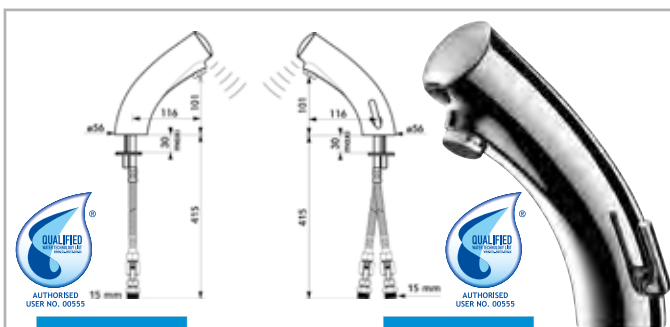

DLB-44200615

DLB-49200615

TEMPOMATIC Mix 3 / TEMPOMATIC 3

Electronic mixer or tap for washbasins with 6V Lithium battery, solenoid valve and electronic controls integrated in the body of the tap. Infra-red presence detection.

- WRAS-approved
- Flow straightener set at 3 lpm at 3 bar. Flow rate can be adjusted if the pressure < 3 bar.
- PEX flexibles with integrated filters.
- Chrome-plated brass body with reinforced fixings.
- Anti-blocking safety & temp. limiter.
- Duty flush (for ~60 seconds 24 hours after the last use).

Model	Description
DLB-44200615	TEMPOMATIC 3, battery-operated tap (non mixer) - Mixer Valves can be fitted, if required.
DLB-49200615	TEMPOMATIC Mix 3, battery-operated tap (mixer)



DLB-378-015

DLB-378MCH

BINOPTIC Mix / BINOPTIC - MAINS supply models

Deck-mounted electronic basin tap.

- WRAS-approved
- Independent IP65 electronic control unit.
- 230/12V mains supply with transformer.
- 15mm connector for compression fittings.
- Flow rate pre-set at 3 lpm at 3 bar, can be adjusted from 1.5 to 6 lpm.
- Scale-resistant flow straightener.
- Adjustable duty flush (pre-set flush ~60 sec. every 24hr after last use).
- Active, infrared presence detection, sensor at the end of the spout optimises detection.
- Chrome-plated brass body.
- PEX flexible with filter and solenoid valve.
- Reinforced fixing.
- Anti-blocking safety.
- Spout with smooth interior and low volume of water (reduces bacterial niches).
- Side temperature control with adjustable maximum temperature limiter (378MCH15 model only).

Model	Description
DLB-378-015	BINOPTIC sensor tap - MAINS supply model
DLB-378MCH	BINOPTIC mixer tap - MAINS supply model

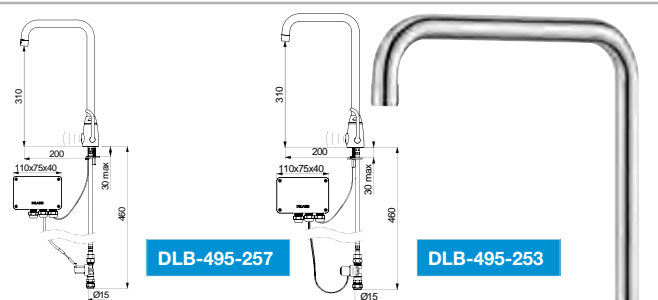

DLB-495-257

DLB-495-253

TEMPOMATIC MIX PRO

Electronic mixer for washbasins with removable swivel spouts L200 H310 and infra-red presence detection.

- Flow straightener set at 3 lpm at 3 bar. Flow rate can be adjusted if pressure < 3 bar.
- PEX flexibles with filters and solenoid valves M1/2".
- Chrome-plated brass body with reinforced fixing.
- Separate IP65 electronic control unit (with integrated transformer 230/12V).
- Removable spout (for sterilisation in the medical sector).
- Automatic duty flush (for ~60 seconds 24 hours after the last use).
- Two shut-off modes available on 230/12V models:
 - > Standard mode: timed flow with automatic shut-off.
 - > ON/OFF mode: voluntary shut-off or after 30 minutes of flow.

Model	Description
DLB-495-253	TEMPOMATIC MIX PRO - electronic basin mixer with swivel spout; mains power supply 230/12V w/transformer
DLB-495-257	Same as 495 25315, but battery-operated (6V Lithium batteries)



WATER



GAS



ENVIRONMENT



PEST CONTROL

ELECTRONIC, HANDS FREE TAPS & ACCESSORIES

DELABIE

PANEL MOUNTED - MAINS & BATTERY-OPERATED BASIN TAPS



DLB-379-D13

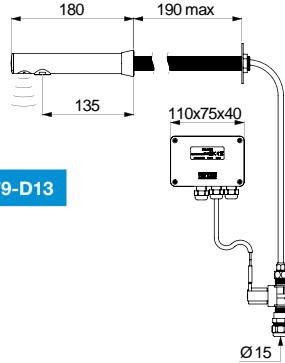

BINOPTIC

Cross wall electronic basin mixer.

- Independent IP65 electronic control unit.
- 230/12V mains supply with transformer.
- Flow rate pre-set at 3 lpm at 3 bar, can be adjusted from 1.5 to 6 lpm.
- Scale-resistant flow straightener.
- Adjustable duty flush (pre-set flush ~60 sec. every 24hr after last use).
- Active, infrared presence detection, sensor at the end of the spout optimises detection.
- Filters and solenoid valves.
- Chrome-plated brass body and spout.
- Anti-blocking safety.
- Spout with smooth interior and low volume of water (reduces bacterial niches).
- Mixer valves can be fitted, if required.

Model	Description	WRAS
DLB-379-D13	L 135mm spout for cross wall installation ≤ 190mm, 15mm connector for compression fittings	
DLB-379-DER	as above with spout L 205mm	
DLB-379-ENC	L 200mm spout for recessed installation, M 3/8" fittings	

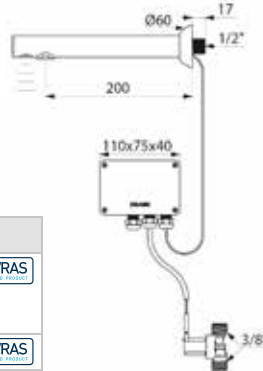

DLB-379-ENC

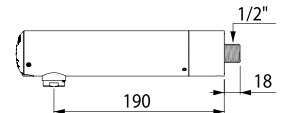

TEMPOMATIC 3

Wall-mounted electronic basin tap.

- Battery-operated with integrated 223 6V Lithium battery.
- Reduced-stagnation solenoid valve and electronic unit integrated into the body of the tap.
- Flow rate pre-set at 3 lpm at 3 bar, can be adjusted from 1.5 to 6 lpm.
- Scale-resistant flow straightener.
- Duty flush (~60 sec. every 24hr after last use).
- Active, infrared presence detection, sensor at the end of the spout optimises detection.
- Chrome-plated solid brass body.
- Cap fixed in place by 2 concealed screws, with pictogram to identify the sensor easily.
- Wall-mounted, M1/2".
- Ø 50mm, L. 190mm.
- Anti-blocking safety.
- 10-year warranty.

Model	Description	WRAS
DLB-443-006	Spout length 190mm	

HYGIENE LINE HANDS FREE CONTACT

TEMPOGENOU - Knee-operated valves

Model	Description	WRAS
DLB-734-100	Angle type from the wall inlet	
DLB-735-400	Straight type in line inlet/outlet	

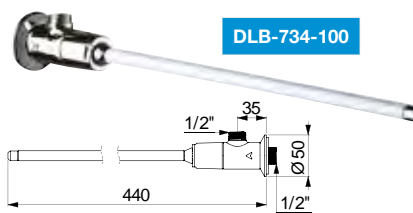

DLB-734-100

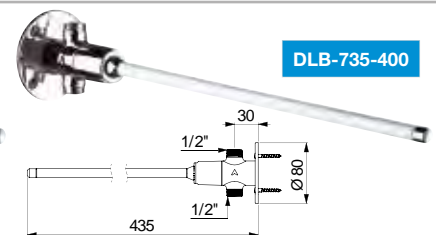

DLB-735-400

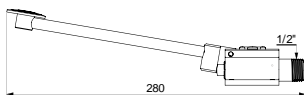

DLB-736-101

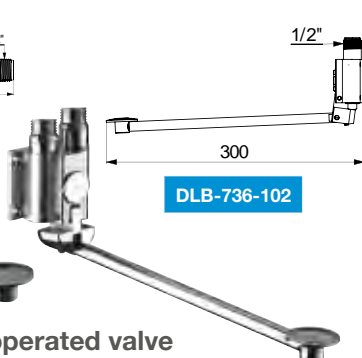

DLB-736-102

MONOFOOT - Pedal-operated valve

Model	Description
DLB-736-101	Floor mounted
DLB-736-102	Wall mounted (height of pedal is adjustable)

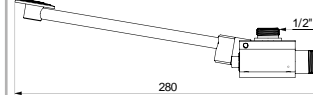

DLB-739-100

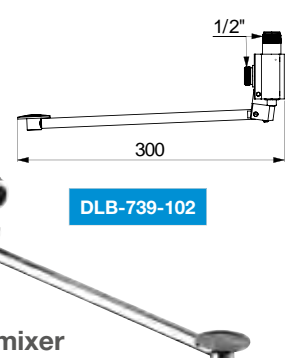

DLB-739-102

MIXFOOT - Pedal-operated mixer

Model	Description
DLB-739-100	Floor mounted
DLB-739-102	Wall mounted (height of pedal is adjustable)



WATER



GAS



ENVIRONMENT



PEST CONTROL

PRE-MIXERS (MIXER VALVES)

PREMIX® COMPACT

Thermostatic mixing valve for mixed water distribution between 30 and 60°C.

- Adjustable temperature from 30-60 °C, can be blocked by the installer.
 - Anti-scalding safety: immediate shut-off if cold water supply fails.
 - Minimum flow rate required to operate: 5 lpm
 - Integrated non-return valves.
- Thermal shocks can be undertaken without special equipment.



DLB-733-020

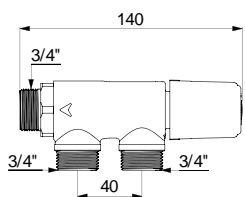

DLB-733-015

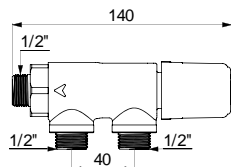

Model	Description
DLB-733-015	Thermostatic Mixing Valve - 1/2-inch
DLB-733-020	Thermostatic Mixing Valve - 3/4-inch

PREMIX® NANO

Thermostatic mixing valve for mixed water distribution between 34 and 60°C.

- For 1 to 2 tap or 1 shower.
 - Anti-scalding safety: immediate shut-off if cold water supply fails.
 - Temperature pre-set at 38°C, can be adjusted by the installer from 34 - 60°C.
 - Integrated non-return valves and filters.
 - Minimum flow rate for operation: 3 lpm.
 - Thermal shocks are possible.
- Buildcert Approval no. BC1430/0814. WRAS No. 1409058.



DLB-732-115

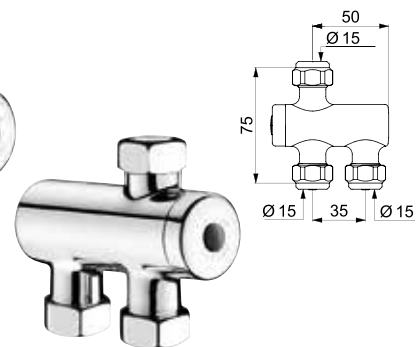

DLB-732-116

Model	Description
DLB-732-115	Nickel-plated body M1/2", 15mm
DLB-732-116	Polished chrome body M1/2", 15mm

NB: Water supplies to mixer valves - operating pressures to be between 1 and 5 bar. Supplies to be balanced. Max difference 1 bar.

COMPACT MIXER

For individual washbasins, to be installed underneath the washbasin.

- 1/2" BSP(MF) with non-return valves and filters.
- Nickel body.
- Integrated stopcocks (function can be easily checked) and filters.

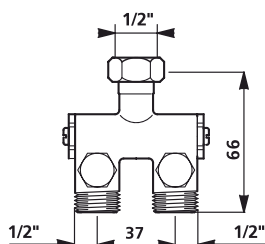

Model	Description
DLB-200-000	Manual Mixer - compact Nickel-plated, MF 1/2-inch with non-return valves & filters



WATER



GAS



ENVIRONMENT



PEST CONTROL

ELECTRONIC, HANDS FREE TAPS & ACCESSORIES

DELABIE

MAINTENANCE PARTS



F

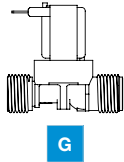

G



N

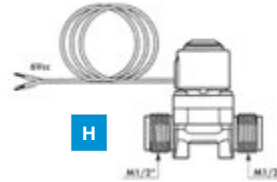

H



I

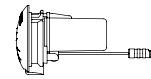

P



K

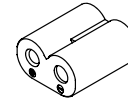

Q



L

Model	Image	Description
DLB-729-308		Cartridge for deck mounted Soap Dispensers - Models 729 008, 729 508, 729 108
DLB-729-312		Cartridge for deck mounted Soap Dispensers - Model 729 012
DLB-729-302		Seal Kit for Soap Dispensers
DLB-753-736	F	Maintenance Washer Bag for MONOFOOT
DLB-753-739	F	Maintenance Washer Bag for MIXFOOT
DLB-495-626	G	For TEMPOMATIC & BINOPTIC - Solenoid Valve, 230/12V
DLB-495-646	H	For TEMPOMATIC & BINOPTIC - Solenoid Valve, 6V
DLB-492-646	N	For TEMPOMATIC 3 BINOPTIC - Solenoid Valve, 6V
DLB-495444	I	For TEMPOMATIC & BINOPTIC - Standard Electronic Control Box
DLB-495445	I	For TEMPOMATIC & BINOPTIC - Multi-Function Electronic Control Box
DLB-495446	I	For TEMPOMATIC & BINOPTIC - 6V Battery Electronic Control Box
DLB-492-446	P	For TEMPOMATIC 3 models, electronic control box, 6V
DLB-495-070	K	For TEMPOMATIC & BINOPTIC - Tempomatic Sensor with Wire, 700mm
DLB-495-149	K	For TEMPOMATIC & BINOPTIC - Tempomatic Sensor with Wire, 1500mm
DLB-495-499	K	For TEMPOMATIC & BINOPTIC - Tempomatic Sensor with Wire, 5000mm
DLB-990-223	Q	For TEMPOMATIC 3 models, 6V Lithium batteries - (CR P2 6V battery)
DLB-925-622.2P	L	Scale & Vandal Proof Flow Restrictors (Aerator) F22
DLB-925-624.2P	L	Scale & Vandal Proof Flow Restrictors (Aerator) M24
DLB-823-012		Non-Return Valve M 1/2-inch M 3/8-inch with filter
TEMPO-CAP		End cap for TEMPOMATIC 3 taps